

The Heart of the PeriTec System

WHEAT DEBRANNING

VTA12SRD-T / VTA16SRD-T / VTA20SRD-T



VTA16

The design concept of the Satake Debranner, VTA series is the result of the accumulation of many years of vertical milling engineering expertise. This machine incorporates all of our modern techniques of vertical milling and has been proven to be "The" machine in many major mills throughout the United States, Europe and Asia. The versatility of the VTA for milling all degrees of bran removal has given the industry the ideal machine.

FEATURES:

1. Introduction:

The Satake VTA is a high capacity machine designed for removing the outer bran and husk layers from cereals such as wheat, barley, and rye by abrasion. The machine is exceptionally hard wearing and is designed for trouble-free 24-hour production.

2. Operating Principle

The stock enters the VTA via a milling chamber regulator valve. The product works its way between the abrasive stones, vertical resistance bars and screen. An exhaust connection on the machine pulls removed bran and dust through the screens and onwards to be collected in a cyclone or dust filter. The degree of milling is controlled by a weighted outlet gate and can be adjusted in seconds.

3. Combination

The machine can be used as "Stand Alone". For very high debranning rates the VTA can be used in conjunction with other VTA or VCV machines

VTA WHEAT DEBRANNER



VTA12

Specifications

Model	VTA12SRD-T	VTA16SRD-T	VTA20SRD-T
Input Capacity (t/h) *1	5 - 6	6 - 8	8 - 10
Required Power (kW)	45 - 75 (4P)	55 - 90 (4P)	75 - 90 (4P)
Required Air Volume (m ³ /min)	50 - 70	70 - 90	90 - 110
Required Static Pressure (kpa)	-1.0 - 1.5		

*1 Input Capacity depends on material.

Dimensions

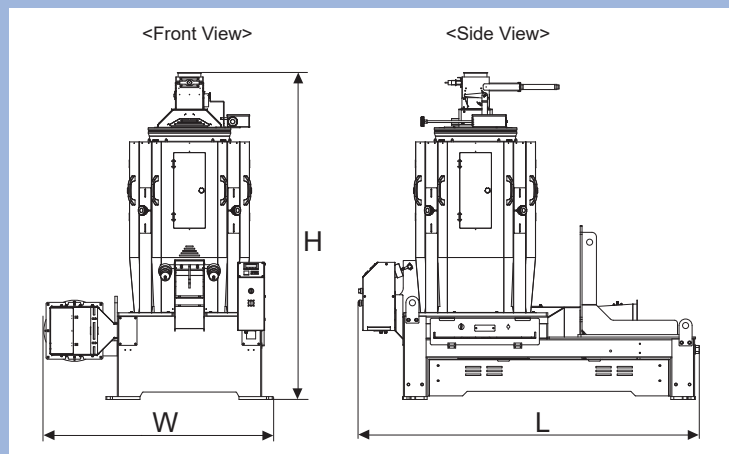

Model	W(mm)	L(mm)	H(mm)	Weight(kg)*1
VTA12SRD-T	1,512	2,250	2,157	1,550
VTA16SRD-T	1,512	2,250	2,203	1,690
VTA20SRD-T	1,541	2,390	2,460	1,950

*1 Approximate Net Weight (Without Motor)

All Satake products are the subject of continuous development and, as a result, their specification may change and differ in detail from those shown.

SATAKE EUROPE LTD

Horsfield Way, Bredbury Industrial Park, Bredbury, Stockport, Cheshire, SK6 2SU. U.K.
www.satake-europe.com sales@satake-europe.com

SATAKE CORPORATION

Head Office
 2-30 Saijo Nishihonmachi,
 Higashi-Hiroshima-shi, Hiroshima-ken,
 739-8602, Japan
 URL : <https://satake-group.com>

Korea Branch
 Daekyo Building, 16F, 239,
 Daedeok-daero, Seo-gu, Daejeon,
 35229, Korea
 URL : <https://satake-group.com>

SATAKE USA INC.
 10900 Cash Road,
 Stafford, Texas, 77477, U.S.A.
 URL : www.satake-usa.com

SATAKE INDIA ENGINEERING PVT. LTD.
 4th Floor, Tower-1, HB Twin Towers, A2,
 3, 4, Netaji Subhash Place, Wazirpur
 District Centre, New Delhi, 110034, India
 URL : www.satakeindia.com

SATAKE (THAILAND) CO., LTD.
 133,134 Moo 5, Bangkadi, Mueang
 Pathum Thani, Pathum Thani 12000,
 Thailand
 URL : www.sataketh.com

SATAKE ASIA CO., LTD.
 No. 101, True Digital Park Griffin Building,
 14th Floor, Unit No. 1407, Sukhumvit Rd.
 Bangchak, Phra Khanong, Bangkok,
 10260, Thailand

PT. SATAKE GOBEL INDONESIA
 Gedung Surabaya Bumi Mandiri, Lantai
 9, Jalan Jenderal Basuki Rachmat
 Nomor 129-137, Unit 905 B, Indonesia
 URL : <https://satake-group.com>

SATAKE VIETNAM CO., LTD.
 1st Floor, Saigon Port Building, No. 03
 Nguyen Tat Thanh Street, Ward 13,
 District 4, HCMC, Vietnam
 URL : <https://satakevietnam.com>

SATAKE MANUFACTURING (SUZHOU) CO., LTD.
 229 Jin Feng Road, Suzhou New
 District, Suzhou City, Jiangsu Province,
 215129, China
 URL : www.satake.cn

SATAKE AUSTRALIA PTY. LTD.
 15 Leland Street, Penrith, N.S.W.,
 2750, Australia
 URL : www.satake.com.au

SATAKE AMERICA LATINA LTDA.
 Rua Xavantes, 155-Pav. 20, Bairro
 Atiradores, CEP 89203-210, Joinville,
 Santa Catarina, Brazil
 URL : www.satake.com.br

ISO 9001 Certification
 (Quality Management Systems)

ISO 14001 Certification
 (Environmental Management Systems)

SATAKE CORPORATION has obtained
 ISO9001 and ISO14001 certification.
 These international standards for
 management systems ensure Satake will
 continue to provide high quality products

All copyright and trademark rights of this catalog belong to Satake Co., unless otherwise noted. Unauthorized copying, reprinting, etc. are forbidden.
 No. 7030-W - SEU