

New Milling Equipment for Versatile Uses

# VERTICAL RICE WHITENER

VTA7SR-T / VTA9SR-T / VTA12SR(2)-T / VTA16SR(2)-T / VTA20SRW-T



VTA20SRW-T

Satake innovates continuously and creates a marvel repeatedly. The new rice whitener is the latest in the list.

This machine improves on existing design and incorporates various improvements to suit long grain milling in a gentle manner.

## FEATURES:

### 1. Gentle Milling :

The new design of VTA machine incorporates gentle milling of brown rice over a larger milling surface in the machine. This also ensures a greater whiteness per brake of VTA in a process.

### 2. Improved Bran Dissipation :

The inclusion of secondary air in the milling chamber ensures greater and much quicker removal of bran from the screens. This provides improved performance of screens in a continuous operation.

### 3. Lower Milling Temperatures :

Due to improved design for air circulation inside the milling chamber and greater aspiration through the bran duct, the temperature inside the milling chamber is greatly reduced. This retains the good characteristics of rice while it is milled gently.

### 4. Automation and Ease of Operation :

The new VTA design can apply optional features which enables this to integrate seamlessly with the plant automation providing a fully remote and automatic operation to the mill.

## VERTICAL RICE WHITENER



VTA7SR-T  
VTA9SR-T  
VTA12SR(2)-T

VTA16SR(2)-T  
VTA20SRW-T

### Specifications

MODEL	VTA7SR-T	VTA9SR-T	VTA12SR(2)-T	VTA16SR(2)-T	VTA20SRW-T
Input Capacity (t/h) <sup>1)</sup>	4.5 ~ 6.0	5.5 ~ 7.0	7 ~ 9	10 ~ 12	12 ~ 15
Required Power (Kw)	37 ~ 45 (4P)	37 ~ 45 (4P)	45 ~ 75 (4P)	55 ~ 90 (4P)	75 ~ 90 (4P)
Required Air volume (m <sup>3</sup> /min)	60	50 ~ 60	70 ~ 90	110 ~ 120	110 ~ 120
Required static pressure (kpa)	-1.0 ~ -1.5	-1.0 ~ -1.5	-1.0 ~ 1.5	-1.0 ~ 1.5	-1.0 ~ -1.5

<sup>1)</sup>Input capacity depends on material.

### Dimensions

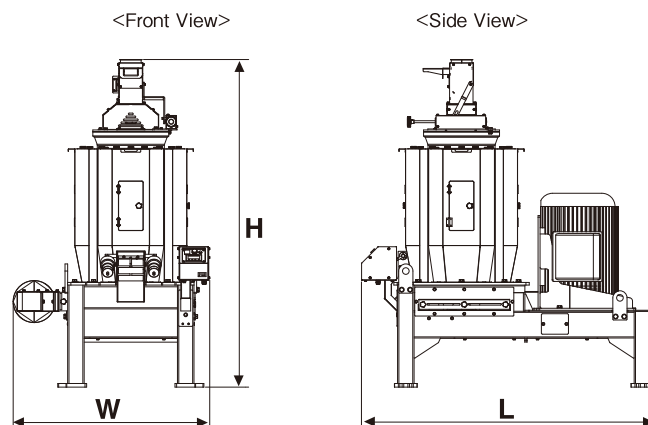

MODEL	W(mm)	L(mm)	H(mm)	Weight(Kg) *1
VTA7SR-T	1200	1820	1990	700
VTA9SR-T	1200	1820	1990	700
VTA12SR(2)-T	1512	2250	2157	1550
VTA16SR(2)-T	1507	2220	2326	1750
VTA20SRW-T	1596	2292	2444	2170

\*Approximate net weight (without motor)

All copyright and trademark rights of this catalog belong to Satake Co., unless otherwise noted. Unauthorized copying, reprinting, etc. are forbidden. All Satake products are the subject of continuous development and, as a result, their specification may change and differ in detail from those shown.

## SATAKE CORPORATION

#### Head Office

2-30 Saijo Nishihonmachi,  
Higashi-Hiroshima-shi, Hiroshima-ken,  
739-8602, Japan  
URL : <https://satake-group.com/>

#### Korea Branch

Alpha mighty Dunsan Building, 16F,  
239, Daedeok-daero, Seo-gu, 35229  
URL : <https://satake-group.com/>

#### SATAKE USA INC.

10900 Cash Road,  
Stafford, Texas, 77477, U.S.A.  
URL : [www.satake-usa.com](http://www.satake-usa.com)

#### SATAKE AMERICA LATINA LTDA.

Rua Xavantes, 155-Pav. 20, Bairro  
Atiradores, CEP 89203-210, Joinville,  
Santa Catarina, Brazil  
URL : [www.satake.com.br](http://www.satake.com.br)

#### SATAKE EUROPE LTD.

Horsfield Way, Bredbury Industrial Park,  
Bredbury, Stockport, Cheshire, SK6 2SU,  
U.K.  
URL : [www.satake-europe.com](http://www.satake-europe.com)

#### SATAKE INDIA ENGINEERING PVT. LTD.

4th Floor, Tower-1, HB Twin Towers, A2,  
3, 4, Netaji Subhash Place, Wazirpur  
District Centre, New Delhi, 110034, India  
URL : [www.satakeindia.com](http://www.satakeindia.com)

#### SATAKE (THAILAND) CO., LTD.

133,134 Moo 5, Bangkadi, Mueang  
Pathum Thani, Pathum Thani 12000,  
Thailand  
URL : [www.satake-th.com](http://www.satake-th.com)

#### SATAKE ASIA CO., LTD.

No. 101, True Digital Park Griffin Building,  
14th Floor, Unit No. 1407, Sukhumvit Rd.,  
Bangchak, Phra Khanong, Bangkok 10260 Thailand  
URL : [www.satake-th.com](http://www.satake-th.com)

#### PT. SATAKE GOBEL INDONESIA

Gedung Surabaya Bumi Mandiri, Lantai  
9, Jalan Jenderal Basuki Rachmat Nomor  
129-137, Unit 905 B, Indonesia  
URL : <https://satake-group.com/>

#### SATAKE VIETNAM CO., LTD.

Copac Square 12 Ton Dan street, Floor  
3A, Ward 13, District 4, HCMC, Vietnam  
URL : <https://satakevietnam.com/>

#### SATAKE MANUFACTURING (SUZHOU) CO., LTD.

229 Jin Feng Road, Suzhou New  
District, Suzhou City, Jiangsu Province,  
215129, China  
URL : [www.satake.com](http://www.satake.com)

#### SATAKE AUSTRALIA PTY. LTD.

15 Leland Street, Penrith, N.S.W.,  
2750, Australia  
URL : [www.satake.com.au](http://www.satake.com.au)

ISO 9001 Certification  
(Quality Management Systems)

ISO 14001 Certification  
(Environmental Management Systems)

SATAKE CORPORATION has obtained  
ISO9001 and ISO14001 certification.  
These international standards for management  
systems ensure Satake will continue to provide  
high quality products and services.