

New Paddy Husker

# PADDY HUSKER

HR10FH-T



**SATAKE CORPORATION**

## Designed with our Customer in Mind

Satake, as a total food engineering company, introduces its unique technologies into the new Paddy Husker HR10FH-T. It achieves the highest levels of performance and functionality.

### **FEATURES and BENEFITS:**

---



#### **1. Feeder**

The vibratory feeder, proved in the color sorter, is introduced. It simultaneously provides smooth, consistent and high throughput. It is equipped with a feeder volume control which can vary the flow rate in a continuous linear manner.



#### **2. Chute**

The new chute is designed to be automatically controlled in the best orientation. It maintains the paddy on the chute in a uniform and consistent stream. Compared with others it offers improved husking efficiency and recovery.

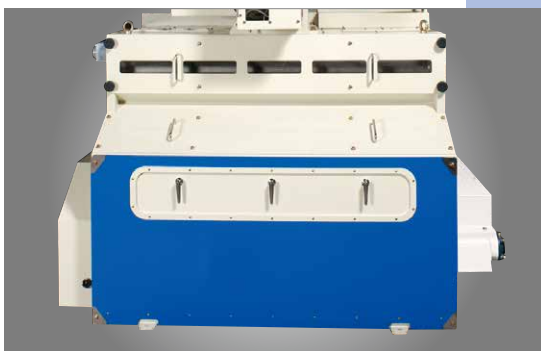

#### **3. Aspirator**

The wide body and adjustable distribution valve further improves the capacity and efficiency. The outlet for immature grain is eliminated because of the excellent separation of rice from husk.



#### **4. Concept**

Functionality and maintainability have been considered. We have introduced a step and a retainer for rolls and tools for ease of roll replacement. There are inspection windows both in front and rear of the Aspirator. Removable inspection covers on both the right and left side of the aspirator body assist easy maintenance.

## And more

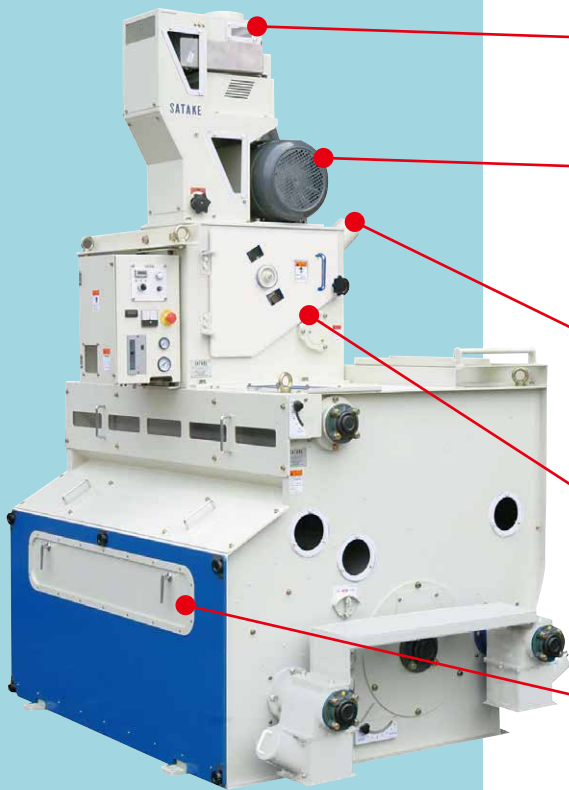

### Capacitance Level Sensor

Space efficient and accurate.

### Motor Mounting

A simple tension pulley provides sufficient adjustment thus eliminating the motor base angle adjustment.

### Dust Exhaust

The air flow is redesigned to assist the smooth feeding of paddy to the rolls.

### Husker Position

Relocated back to the center of the Aspirator for even and stable distribution of husked rice.

### Inspection Cover

Removable for maintenance. Light in weight for the operators' convenience.

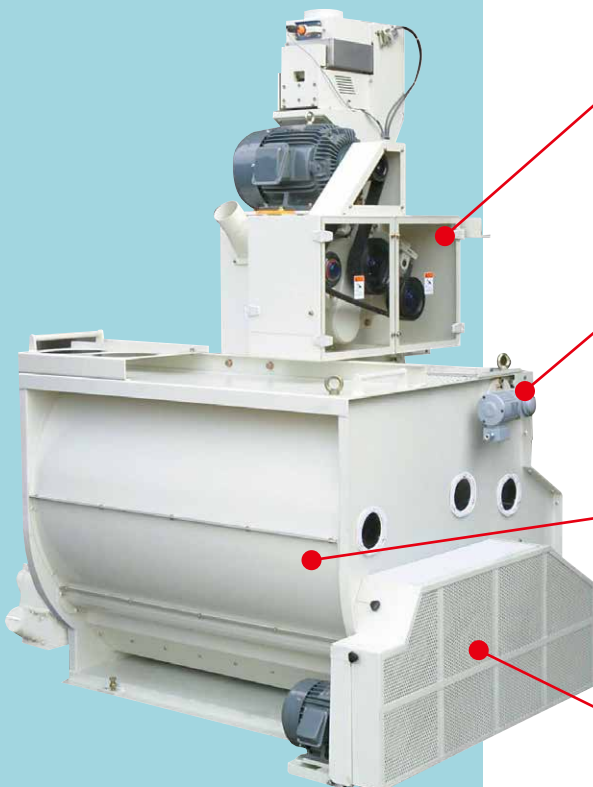

### Acrylic Drive Cover

Totally enclosed but observable.  
The new cover is superior in strength.

### Geared Motor Direct Coupling

The simplified belt routing enables observation from behind.

### Detachable Round Body and Screw Casing

Maintenance from the other side is possible.  
Easy to clean husk outlet.

### New Motor Layout

Makes tensioning simple and easy.

# PADDY HUSKER HR

## PADDY HUSKER

### Specifications

Model		HR10FH-T
Component (Husker & Aspirator)		HU10FH-T+HA10W-T
Input Capacity (t/h)	Short Grain Rice	4.0~6.0
	Medium Grain Rice	4.0~6.0
	Long Grain Rice	3.5~5.0
	Basmati (Non-Parboiled)	2.5~3.0
	Basmati (Parboiled)	2.5~3.5
Required Power(kW)		HU:7.5+0.052 HA:3.7+0.1

### Dimensions

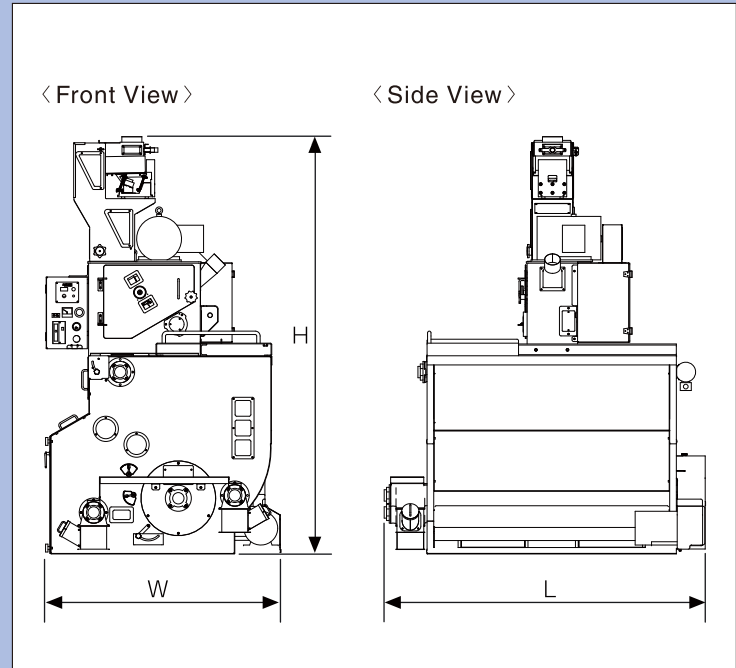

Model	W(mm)	L(mm)	H(mm)	Net Weight (kg)
HR10FH-T	1,550	2,040	2,650	1,190

All Satake products are the subject of continuous development and, as a result, their specification may change and differ in detail from those shown.

## SATAKE CORPORATION

**Head Office**  
2-30 Saijo Nishihonmachi,  
Higashi-Hiroshima-shi, Hiroshima-ken,  
739-8602, Japan  
URL : [www.satake-group.com](http://www.satake-group.com)

**SATAKE USA INC.**  
10900 Cash Road,  
Stafford, Texas, 77477, U.S.A.  
URL : [www.satake-usa.com](http://www.satake-usa.com)

**SATAKE AMERICA LATINA LTDA.**  
Rua Xavantes, 155-Pav. 20, Bairro  
Atradores, CEP 89203-210, Joinville,  
Santa Catarina, Brazil  
URL : [www.satake.com.br/](http://www.satake.com.br/)

**SATAKE EUROPE LTD.**  
P.O. Box 53, Horsfield Way, Bredbury  
Industrial Park, Bredbury, Stockport,  
Cheshire, SK6 2SU, U.K.  
URL : [www.satake-europe.com](http://www.satake-europe.com)

**SATAKE INDIA ENGINEERING PVT. LTD.**  
4th Floor, Tower-1, HB Twin Towers, A2,  
3, 4, Netaji Subhash Place, Wazirpur  
District Centre, New Delhi, 110034, India  
URL : [www.satakeindia.com/](http://www.satakeindia.com/)

**SATAKE (THAILAND) CO., LTD.**  
133,134 Moo 5, Bangkadi, Mueang  
Pathum Thani, Pathum Thani 12000,  
Thailand  
URL : [www.satake-th.com](http://www.satake-th.com)

**SATAKE INTERNATIONAL BANGKOK CO., LTD.**  
888/84 Mahatun Plaza Bld., 8th Floor,  
Ploenchit Rd., Lumpini, Pathumwan,  
Bangkok, 10330, Thailand

**PT. SATAKE GOBEL INDONESIA**  
Gedung Surabaya Bumi Mandiri,  
Lantai 9, Jalan Jenderal Basuki  
Rachmat Nomor 129-137, Unit 905 B,  
Indonesia

**SATAKE MANUFACTURING (SUZHOU) CO., LTD.**  
229 Jin Feng Road, Suzhou New  
District, Suzhou, Jiangsu Province,  
215129, China  
URL : [www.satake.cn/](http://www.satake.cn/)

**SATAKE AUSTRALIA PTY. LTD.**  
15 Leland Street, Penrith, N.S.W.,  
2750, Australia  
URL : [www.satake.com.au](http://www.satake.com.au)

ISO 9001 Certification  
(Quality Management Systems)

ISO 14001 Certification  
(Environmental Management Systems)

SATAKE CORPORATION has obtained ISO9001 and ISO14001 certification. These international standards for management systems ensure Satake will continue to provide high quality products and services.